



**CB LIFT-050  
QUICK LIFT**

REMOTE CONTROL TV LIFT

120 lb. [54 kg.] Capacity\*

Pre-mounted to backboard for easy installation

**APPLICATIONS:**

Designed to carry up to 50" diagonal flat-panel television screens in audio visual, home theater, or entertainment center cabinetry. **This product is covered by U.S. and foreign patents issued and/or pending.**

**CB LIFT-050**

**QUICK REFERENCE**

Minimum Inside Cabinet Dimensions:

30" width

34" height (overlay)

34.75" height (inset)

10" depth

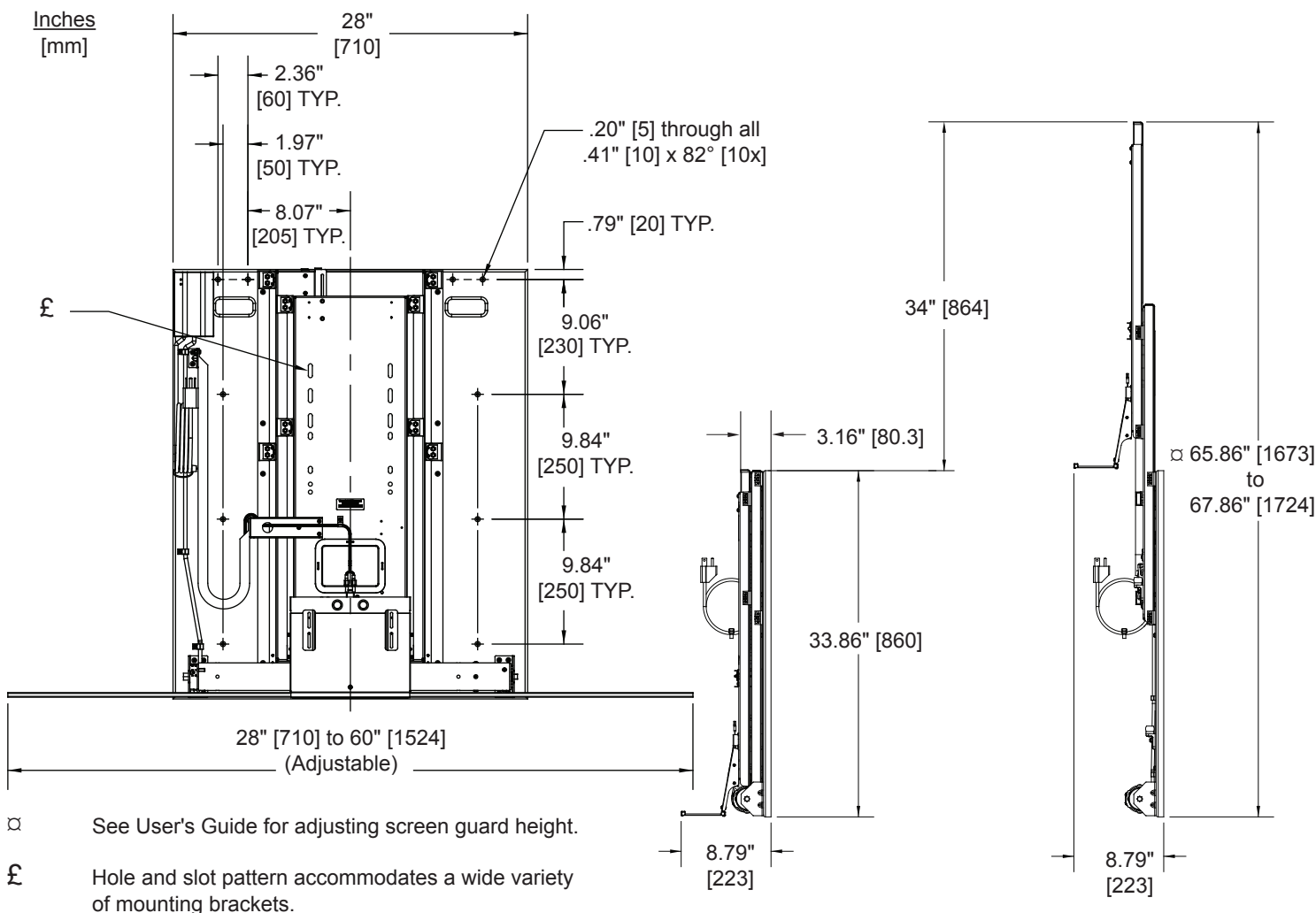

<b>Finish</b>	Black powder coat
<b>Dimensions</b>	Backboard 28" [710 mm] X 33.86" [860 mm]
<b>Travel</b>	34" [864 mm]
<b>Load</b>	120 lbs. [54 kg.]
<b>Hardware</b>	Mounting hardware included. See packaging information on back page.
<b>Features</b>	Hole and slot pattern accommodates a wide variety of mounting brackets.
<b>Also</b>	Optional Fixed Lid Bracket Kit Replacement Remote Controls

\* Load rating based on 5,000 cycles.

## WARNING

### Read All Instructions Before Installing and Operating the Quick Lift

Failure to read and follow the instructions can result in serious personal injury, damage to equipment, or voiding of factory warranty. It is the installer's responsibility to make sure all components are properly assembled and installed using the instructions provided.

**Entrapment/Entanglement Hazard:** When operating the Quick Lift, keep hands, clothing, and hair clear of the apparatus to prevent personal injury or damage to the mechanism.

- Do not operate the Quick Lift outside of a protective cabinet or structure.
- Do not operate without reversal deck. The Quick Lift is equipped with a reversal deck with Auto-Reverse technology that causes the lift to reverse direction if it encounters an obstruction as it lowers.
- Do not operate with plastic protective covers removed.

**Do not overload** or lift may fail and personal injury may result. Maximum load capacity 120 lbs. Accommodates flat-panel television screens up to 50" diagonal and 33.5" tall. Not designed to carry human weight.

- **This product is capable of carrying the stated load when the structure into which it is mounted is designed to safely carry such loads.** The cabinet maker should ensure the final structure is safe and stable when carrying the maximum intended load.
- The Quick Lift assembly must be securely attached to the cabinet/structure walls.
- When fully loaded with the actual intended load, the entire structure must be stable when the lift is fully extended.
- Before operating the Quick Lift, ensure the cabinet/structure is counterbalanced or bolted to the floor or wall to ensure the cabinet/structure does not tip over when the lift is fully loaded and extended.

**Keep Children Clear.** Children should not play on or around the lift to prevent personal injury or damage to the mechanism.

 **Risk of Electric Shock:** The Quick Lift uses live electrical current to operate. To reduce the risk of burns, fire, electric shock, or injury to persons:

- Do not install or service the Quick Lift with the power cord connected.
- Do not install or service the television with the Quick Lift power cord connected.

**Continuous or excessive cycling of the Quick Lift may overheat or damage the motor.**

## Installation Instructions

### Cabinet Requirements

**Height:** 34" minimum [864 mm] inside dimension (overlay)  
34 3/4" minimum [883 mm] inside dimension (inset)

**Width:** 30" minimum opening (inside dimension)

**Depth:** 10" [254 mm] minimum opening (inside dimension)\*\*

**Material**

**Thickness:** 3/4" [19 mm] minimum recommended  
(3/4" maximum for inset lid)

**NOTE:** 15" [381 mm] minimum required distance from centerline to 2" diameter access hole (see illustration).

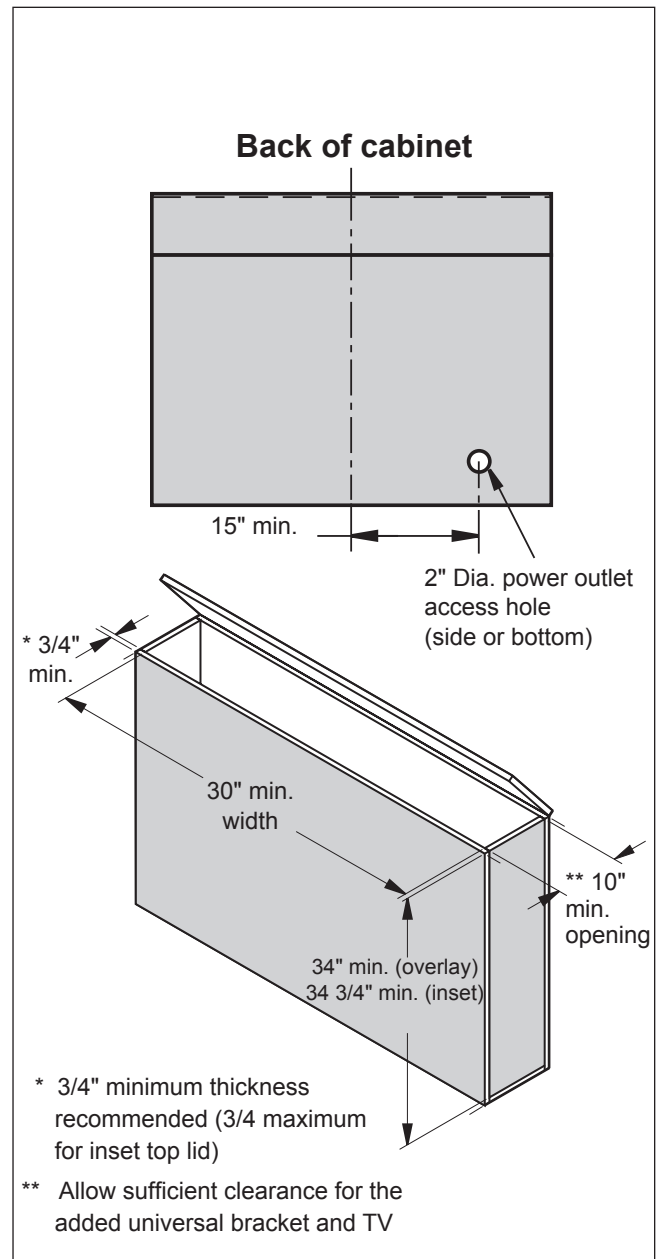

### Cabinet Tops

#### HINGED OVERLAY

Piano hinge recommended for best performance

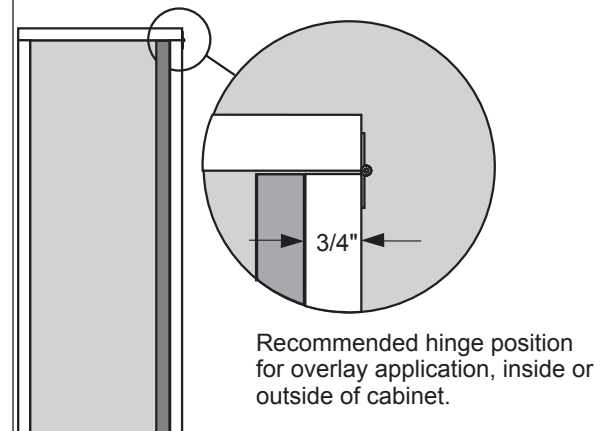

Cabinet Tops (continued)

HINGED TOP INSET

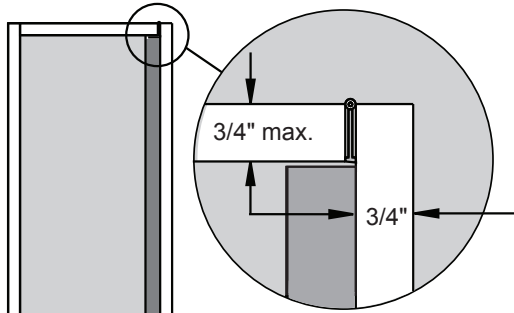

Make sure the top of the cabinet does not interfere with lift mechanism.



**Do not install or service the CB Lift-050 with the power cord connected.**

1. On the inside opening of cabinet, locate and mark a vertical centerline on the mounting surface wall from top to bottom. Locate the center mark of the CB Lift-050 mounting board.
2. Align the centerline of the cabinet with the center mark of the CB Lift-050 mounting board (fig. 1).
3. Set the bottom of the mounting board flush or level with the inside bottom of the cabinet. If the cabinet is taller than 34", mount the Quick Lift near the top opening of the cabinet.
4. Install using 10 flat head wood screws and securely tighten. Mounting board must be securely fastened, allowing no gap between mounting board and cabinet's rear wall.

**NOTE:** The top of the cabinet must be parallel to the top of the moving inner member.

Figure 1

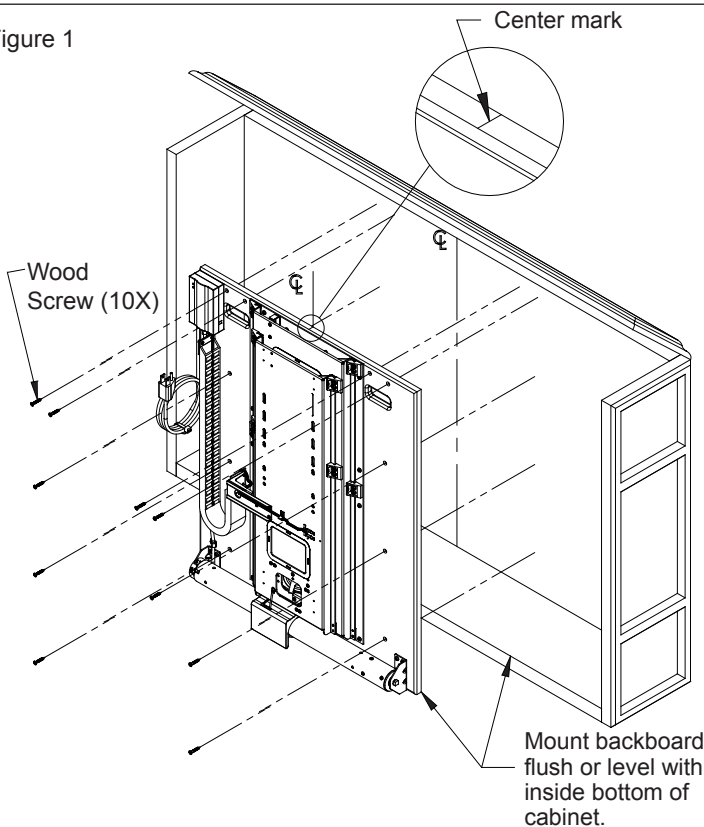

Reversal Deck Assembly

1. Connect to power source and verify operation by control box and remote control.
2. Put lift in the raised position.  
**WARNING: disconnect power after raising lift**
3. Trim aluminum reversal decks so there is minimum of 1/4" clearance between ends of deck and opening. (Opening width ÷ 2) - 1/4" = reversal deck length.

Figure 2

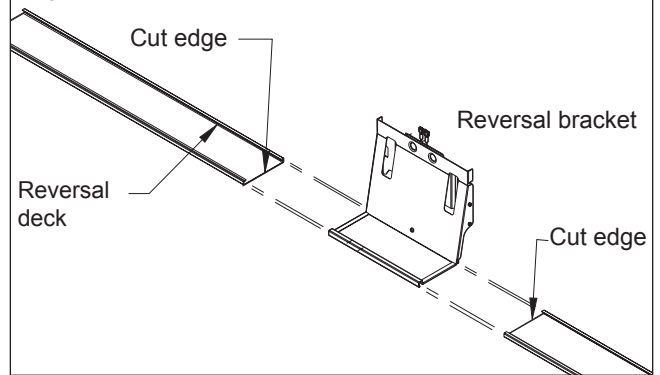

4. Loosen the Phillips screw on the reversal bracket and insert decks, cut edge in (fig. 2).

Figure 3

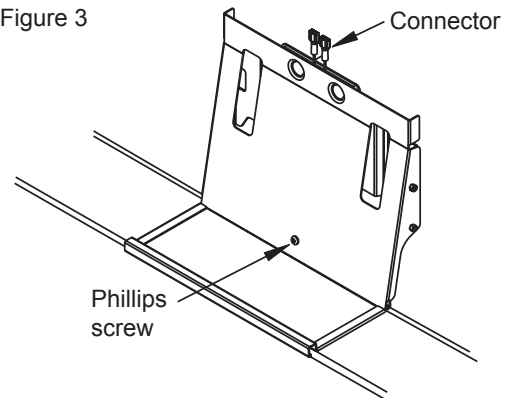

5. Tighten the Phillips screw (fig. 3)

**NOTE:** The reversal deck design allows for 1/4" piece of melamine or wood to be inserted to match cabinetry finish.

Figure 4

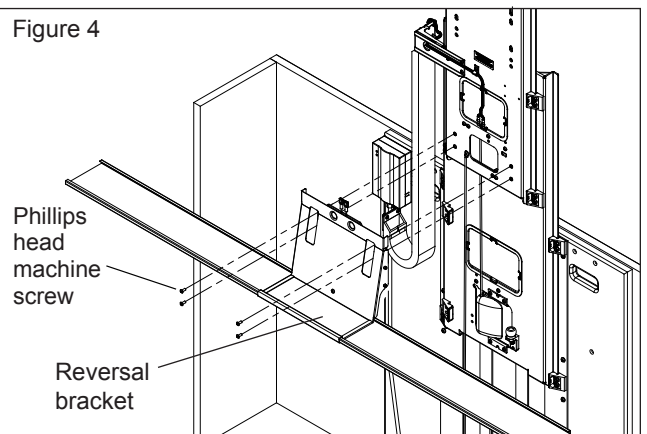

6. Insert (4) Phillips head machine screws through the slots of the reversal bracket and into the four threaded holes located near the bottom of the CB Lift-050 and securely fasten (fig. 4).

**Coupler Connection**

1. Connect the female coupler located on the reversal bracket to the male coupler of the wire (fig. 5).
2. Reconnect power and lower the lift.

Figure 5

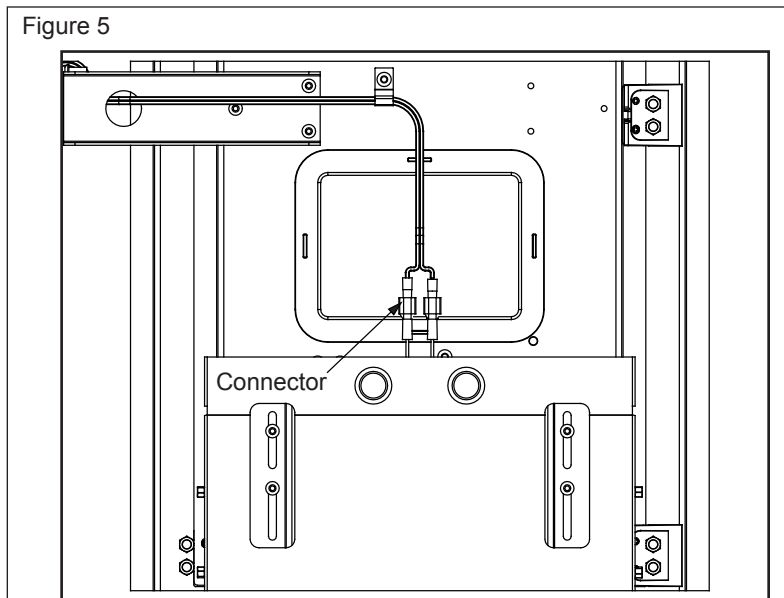

For television bracket installation instructions, see the Quick Lift User's Guide.

**Ordering Instructions**

Order the CB Lift-050 by specifying the following

Total Lifts Required	1 Each
Part Number	CBLIFT-050

**Packaging/Hardware**

10 each	Flat Head Wood Screws
4 each	Phillips Head Machine Screws
1 each	Quick Lift pre-mounted to backboard
1 each	Mounting Bracket Fastener Kit* (bracket not included)
4 each	M8 X 22L Screws
4 each	M8 Lock Nuts
4 each	Washers
1 each	Remote Control*
1 each	Key Fob Remote Control*
2 each	Reversal Decks ■
1 each	Reversal Base Bracket ■
1 each	Quick Installation Guide
1 each	User's Guide*

\* **NOTE:** These items must be provided to the end-user.

**Kits:** Replacement Remote Controls: P/N 4180-0654-XE  
Fixed Lid Bracket Kit: P/N 4180-0650-XE

■ **Reversal Decks/Bracket must be installed to validate warranty.**

**Specifications**

Lift assembly: Cold rolled steel  
Reversal Decks: Black anodized aluminum

**NOTE:** Specifications, materials, prices, terms, and delivery are subject to change without notice.

Accuride's Quick Lift is warranted against defects in workmanship or materials under normal use for four (4) years after date of purchase from an authorized Accuride distributor. This warranty does not extend to remote control devices that may be included with the Quick Lift. Remote control devices are warranted against defects in workmanship or materials for ninety (90) days from date of purchase.

Accuride will repair or replace (as determined by Accuride or its authorized representative at its sole discretion) defective products at no charge to the original purchaser within the warranty period so long as the original purchaser returns the product, shipping prepaid, to Accuride or an authorized Accuride distributor. This represents Accuride's sole warranty obligation to original purchasers of its products.

This warranty is non-transferable. To the maximum extent permitted by applicable law, Accuride disclaims any other warranties, express or implied, including warranties of fitness for a particular purpose and warranties of merchantability. Accuride will not be liable for any damages whatsoever arising out of the use or inability to use the Quick Lift, even if Accuride has been advised of the possibility of such damages. Accuride shall not be responsible for incidental or consequential damages, because some states or jurisdictions do not allow the exclusion or limitation of liability for consequential or incidental damages, the above limitation may not apply. Any repair or modification of the Quick Lift not performed or specifically authorized by Accuride will void the warranty provided above.

Accuride will not be responsible for damage to the Quick Lift caused by misuse, abuse, failure to properly package the product for return to Accuride, or for damage caused by carriers during shipment either to or from Accuride or an authorized Accuride distributor.

This warranty does not extend to any damage to products used in conjunction with the Quick Lift. Any repairs necessitated by misuse, abuse, or shipping damage to the Quick Lift or repairs of defective Quick Lifts returned after the warranty period has expired will be performed at then current rates established by Accuride for factory service.

For repair or replacement of a Quick Lift, please send the damaged unit to the following shipping address, only after obtaining authorization from Accuride International Inc.

**Accuride International Inc.**  
**Attn: Technical Services**  
**12935 Imperial Hwy**  
**Santa Fe Springs, CA 90670**  
**[www.accuride.com](http://www.accuride.com)**



ACCURIDE INTERNATIONAL INC.

12311 Shoemaker Avenue  
Santa Fe Springs, CA 90670

TEL (562) 903-0200  
FAX (562) 903-0208  
[www.accuride.com](http://www.accuride.com)

Manufacturing, Engineering, and Sales  
United States • Germany • Japan • Mexico • United Kingdom • China