

APPLICATIONS: EIA rack-mount chassis, cash drawers, industrial workstations, medical emergency carts, and vending machines. Use model 3308 whenever a medium duty, over travel slide with lock in and out is required.

Medium Duty, Lever Disconnect
Over Travel, Lock-In, Lock-Out
Up to 150 lb. Capacity
Up to [68 kg.] Capacity

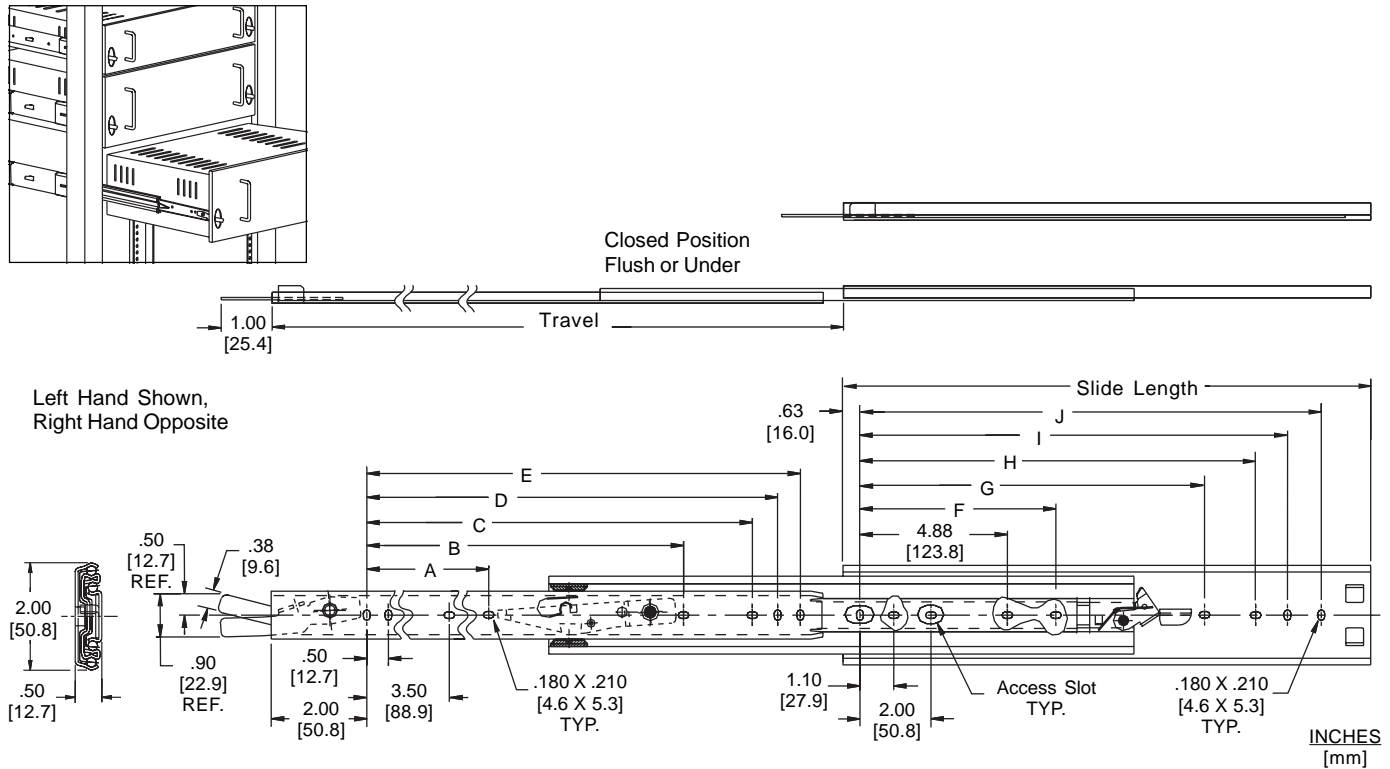

- | | | | |
|-------------------|--|-------------------|---|
| Finish | Bright electro-zinc (C) plating only | Mounting | Bracket or hard mounting |
| Length | 12" - 28" [305mm - 711mm] | Movement | Steel ball bearing |
| Travel | Slide length plus 1" [25.4mm] | Hardware | #8 pan head screw |
| Height | 2.00" [50.8mm] | Disconnect | Lever disconnect |
| Load | See Chart* | Features | Lock in holds chassis closed. Lock out holds chassis fully open. Lead-in pins guide chassis during reinsertion. |
| Side Space | .50" +.015 / -.000
[12.7mm +0.4 / -0.0] | | |

* Load rating based on a 16" wide drawer cycled 10,000 times.

Part Number	Slide Length	Slide Travel	* Load Rating lb. [kg.] per pair	A	B	C	D	E	F	G	H	I	J
3308-12	12.00 [305]	13.00 [330]	150 [68.2]			7.88 [200.1]	8.38 [212.8]	8.88 [225.5]			8.25 [209.5]	9.25 [234.9]	10.25 [260.3]
3308-14	14.00 [356]	15.00 [381]	148 [67.3]			9.88 [250.9]	10.38 [263.6]	10.88 [276.3]			10.25 [260.3]	11.25 [285.7]	12.25 [311.1]
3308-16	16.00 [406]	17.00 [432]	147 [66.8]			11.88 [301.7]	12.38 [314.4]	12.88 [327.1]			12.25 [311.1]	13.25 [336.5]	14.25 [361.9]
3308-18	18.00 [457]	19.00 [483]	146 [66.4]	5.63 [143.0]	11.00 [279.4]	13.88 [352.5]	14.38 [365.2]	14.88 [377.9]	7.00 [177.8]	12.38 [314.4]	14.25 [361.9]	15.25 [387.3]	16.25 [412.7]
3308-20	20.00 [508]	21.00 [533]	145 [65.9]	6.63 [168.4]	13.00 [330.2]	15.88 [403.3]	16.38 [416.0]	16.88 [428.7]	8.00 [203.2]	14.38 [365.2]	16.25 [412.7]	17.25 [438.1]	18.25 [463.5]
3308-22	22.00 [559]	23.00 [584]	140 [63.6]	7.63 [193.8]	15.00 [381.0]	17.88 [454.1]	18.38 [466.8]	18.88 [479.5]	9.00 [228.6]	16.38 [416.0]	18.25 [463.5]	19.25 [488.9]	20.25 [514.3]
3308-24	24.00 [610]	25.00 [635]	135 [61.4]	8.63 [219.2]	17.00 [431.8]	19.88 [504.9]	20.38 [517.6]	20.88 [530.3]	10.00 [254.0]	18.38 [466.8]	20.25 [514.3]	21.25 [539.7]	22.25 [565.1]
3308-26	26.00 [660]	27.00 [686]	127 [57.7]	9.63 [244.6]	19.00 [482.6]	21.88 [555.7]	22.38 [568.4]	22.88 [581.1]	11.00 [279.4]	20.38 [517.6]	22.25 [565.1]	23.25 [590.5]	24.25 [615.9]
3308-28	28.00 [711]	29.00 [737]	120 [54.5]	10.63 [270.0]	21.00 [533.4]	23.88 [606.5]	24.38 [619.2]	24.88 [631.9]	12.00 [304.8]	22.38 [568.4]	24.25 [615.9]	25.25 [641.3]	26.25 [666.7]

Installation Instructions

Instruction to Bracket Mount

- To ensure proper operation of the slides, ensure that all bracket mounting screws (#8-32) are inserted so that the screw heads are inside the slides. (No washers on the inside of the slides.)
- Separate slide members by actuating the disconnect lever. NOTE: Slides are handed.
- Using mounting kits and brackets, mount brackets to slide outer members (largest). For adjustment purposes, screw the back brackets on loosely.
- Install slides into EIA rack with #10 x 32 screws (customer supplied) and secure with bar nuts. Rear adjustment is possible by aligning the back bracket. Do not tighten screws until final adjustment is made.
- Mount slide drawer members (smallest) to the chassis. Position slides 1/8" [3.2mm] from the front edge of the chassis making sure both slides are parallel. Lock-in latch will extend through drawer front cut-out. Ensure right hand and left hand slide members are mounted to mate with correct hand slide.
- With cabinet members in the closed position and retainers fully forward, install chassis by engaging the slide members and close completely. Check slide alignment by opening and closing the chassis. Any sign of binding indicates lateral stress or misalignment.
- Adjust slide position until movement is smooth. Tighten all screws and if necessary, use more screws to secure slides and complete installation.

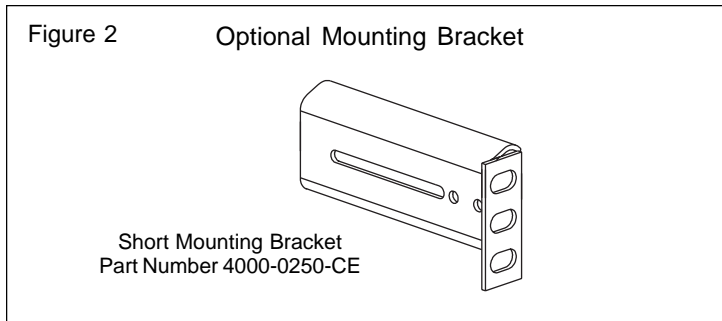
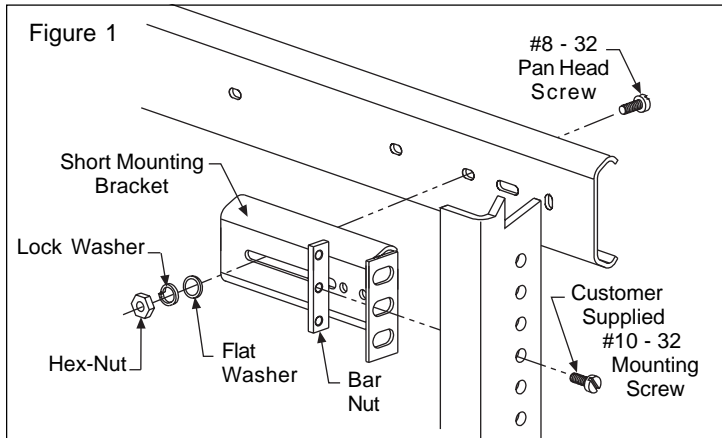

Instructions to Hard Mount

- Follow steps 1 and 2 of "Bracket Mount" instructions.
- With slides fully extended, install slide cabinet members (largest) into cabinet using #8 pan head screws. Ensure slides are parallel.
- Mount slide drawer members (smallest) to the chassis. Leave all screws loose for future adjustment. Ensure slides are parallel and handed members mated properly.
- Follow steps 6 and 7 of "Bracket Mount" instructions.

Copyright © 2002 Accuride International Inc. Printed in U.S.A. 3700-1070(9423)-MK563-R2-0402

Ordering Procedure

Complete your slide order for model 3308 by specifying the following:

Total Slides Required	_____ 10 pair	C 3308	-18	D
Slide Finish	_____			
Slide Model	_____			
Slide Length	_____			
Optional Polybag Packing	_____			

Optional Mounting Brackets

Optional mounting brackets are ordered as **kits** or **bulk**.

Each **kit** contains enough brackets and hardware to mount one pair of slides. Order kit part number 4180-0219-XE.

Total Kits Required	_____ 10 each	4180-0219-XE
Kit Part Number	_____	

Bracket kit includes the following. See Figure 1.

- 4 short brackets (part number 4000-0250-CE)
- 1 bracket hardware kit* (part number 4180-0230-XE)
- (*Kit contains screws, hex-nuts, washers, bar nuts.)

For **bulk**, order 4 each short brackets and 1 hardware kit per pair of slides required. See Figure 2.

Total Brackets Required	_____ 20 each	4000-0250-CE
Bracket Part Number	_____	

Total Hardware Kits Required	_____ 20 each	4180-0230-XE
Hardware Kit* Part Number	_____	
(*Kit contains screws, hex-nuts, washers, bar nuts.)		

Packaging

Distributor (D) Pack: Polybag contains one pair of slides and one slide mounting hardware kit. Brackets ordered separately.

Lengths 12" - 20" 10 pair per box
Lengths 22" - 28" 5 pair per box

Bulk (P) Pack: Slides and optional mounting bracket kit are ordered and packaged separately.

Lengths 12" - 22" 10 pair per box
Lengths 24" - 28" 7 pair per box

Specifications

Slide members and ball retainers: Cold rolled steel

Ball bearings: Carburized steel

Note: Specifications, materials, prices, terms, and delivery are subject to change without notice.

Accuride

ACCURIDE INTERNATIONAL INC.

12311 Shoemaker Avenue
Santa Fe Springs, CA 90670
TEL (562) 903-0200
FAX (562) 903-0208
www.accuride.com
Manufacturing, Engineering, and Sales
United States • Germany • Japan • Mexico • United Kingdom

Copyright © 2002 Accuride International Inc. Printed in U.S.A. 3700-9423(1070)-MK072-R2-0402