

APPLICATIONS: Accommodates a wide range of electronic chassis made by various manufacturers. Accommodates chassis from 1U to 4U, or where chassis weight is less than 120 lbs. **This product is covered by U.S. and various foreign patents issued and/or pending.**

Electronic Enclosure Slide
 Ball Bearing Movement
 .38" [9.6 mm] Width
 1.75" [44.5 mm] Height
 2.00" [50.8 mm] Over Travel
 Up to 120 lbs.* [55 kg.] Capacity

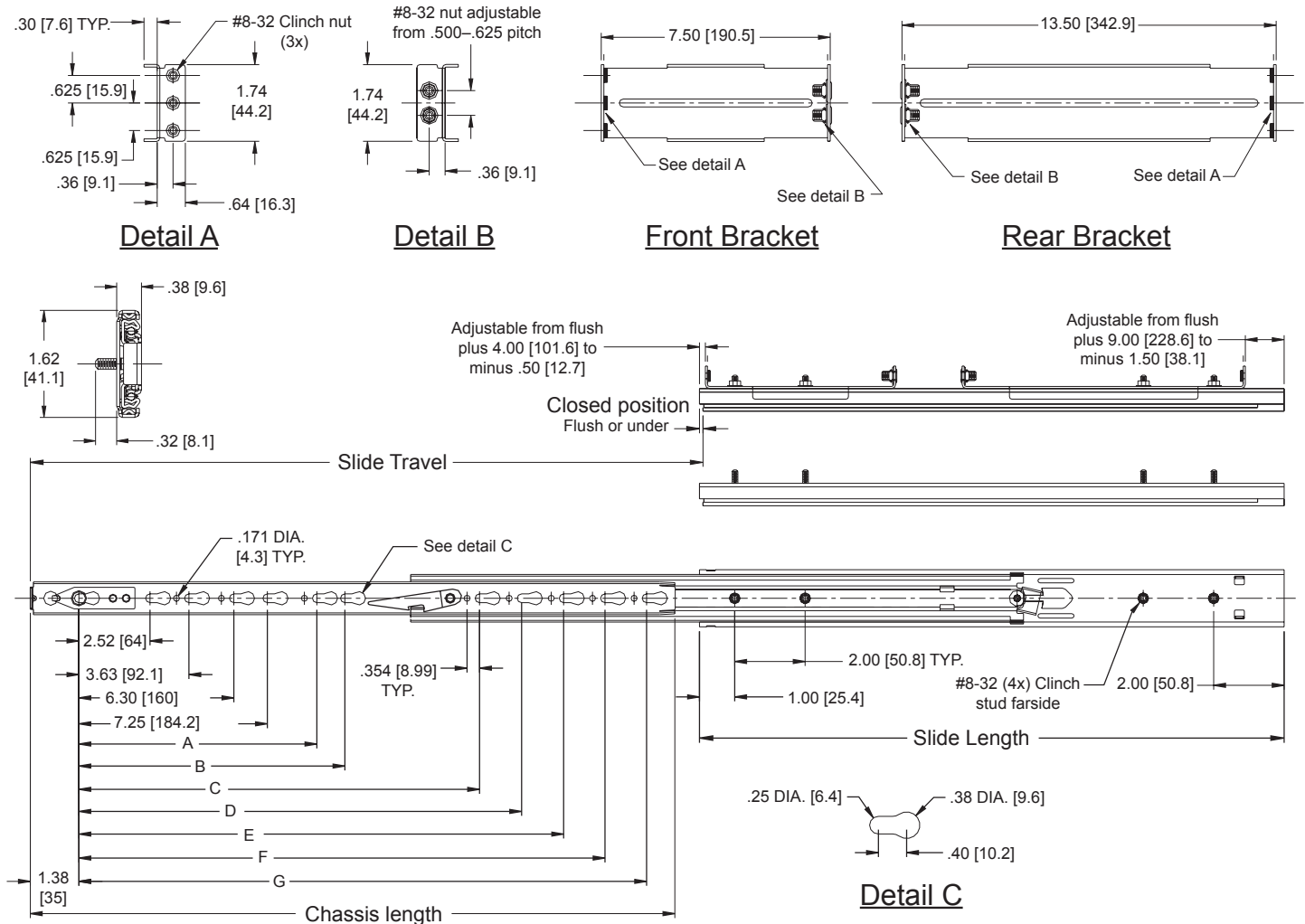

Finish Bright electro-zinc (C) plating

Side Space .38" [9.6 mm]

Length Even lengths 22"–26" [559 mm–660 mm]

Mounting Cabinet Member: Adjustable front and rear brackets.

Height 1.75" [44.5 mm]

Chassis Member: #8 pan head screw or pins (see optional mounting accessories)

Travel 2.00" [50.8 mm] over travel

Features Unhanded, lock-out, disconnect, reversible EIA mounting brackets

Load Up to 120 lbs. [55kg] *

| Part Number | Slide Length | Chassis Length | Slide Travel | A | B | C | D | E | F | G |
|-------------|--------------|----------------|--------------|---------------|---------------|---------------|---------------|---------------|---------------|---------------|
| 22WB | 23.0 [584] | 21.95 [558] | 24.00 [610] | - | - | 14.50 [368.3] | 16.38 [416.0] | 18.13 [460.4] | - | - |
| 24WB | 25.00 [635] | 23.95 [608] | 26.00 [660] | - | - | 14.50 [368.3] | 16.38 [416.0] | 18.13 [460.4] | 20.16 [512.0] | - |
| 26WB | 27.00 [686] | 25.95 [659] | 28.00 [711] | 10.08 [256.0] | 10.88 [276.2] | - | 16.38 [416.0] | 18.13 [460.4] | 20.16 [512.0] | 21.75 [552.5] |

* Load rating based on an 16" [406 mm] wide chassis cycled 2,000 times.

Installation Instructions

- 1) Separate slide chassis members by lifting left hand slide lever up and right hand slide lever down. Keep slide chassis members with original outer members.
- 2) Slide chassis member is installed using first available mounting hole (figure 1). The chassis member set-back is the distance from front of slide to front of chassis. This set-back will be the same when installing the cabinet member front bracket to the slide. Once the set-back dimension is determined, install the front bracket (refer to note 3).
- 3) Cabinet to slide mounting brackets have 3 possible positions to align EIA universal hole pattern (figure 2). Note the fixed 3 hole spacing and the adjustable 2 hole locations (accepts both .50"/12.7 mm and .63"/15.9 mm pitch).
- 4) Cabinet brackets are placed behind the cabinet rail surface (figure 3). Use thumb screw to go through cabinet rail into the slide bracket threaded inserts. If using a tapped rail cabinet, round hole cabinet, or square hole cabinet, the thumb screw will tighten fully against the cabinet rail.
- 5) Determine the inside surface of cabinet rail-to-rail distance (figure 4). Install the slide rear mounting bracket to this distance and loosely tighten hex nuts. Place the slide between the cabinet rails. Install thumb screws to secure slide to the cabinet.
- 6) Install chassis member to the side of the chassis using screws or pins (figure 5). Screws can be installed directly through the slide member. Screws can also be partially installed to side of the chassis. Place the chassis member over the screws and within the keyhole slots, tighten fully. The slide can be secured without tools when using pins. Place slide member over pins within keyhole slots. Push slide member to the rear. Chassis member lock spring will snap over the first pin to secure without tools.
- 7) Extend slide cabinet member to its fully locked position. Bring ball retainer fully forward. Align chassis members with the black plastic lead-in pins. Install chassis by engaging the slide members and close completely. Check slide alignment by opening and closing the chassis. Any sign of binding indicates lateral stress or misalignment. Adjust slide position until movement is smooth. Tighten all screws and complete installation.

NOTE: To remove chassis, lift the lever on the left hand slide up and the lever on the right hand slide down.

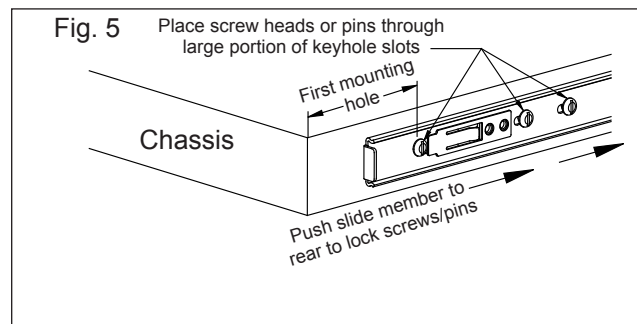
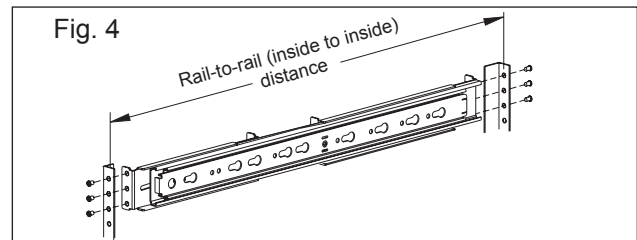
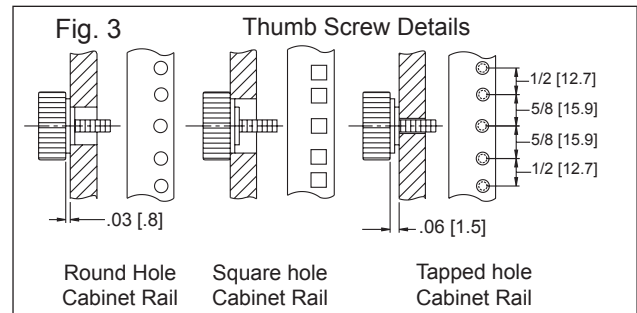
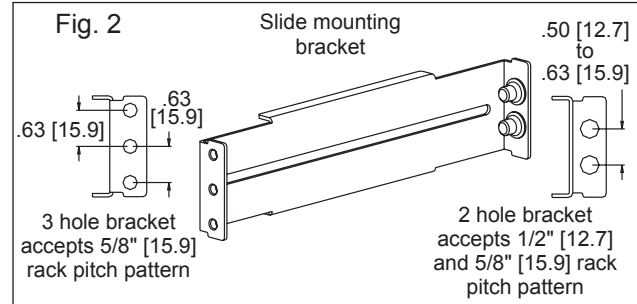
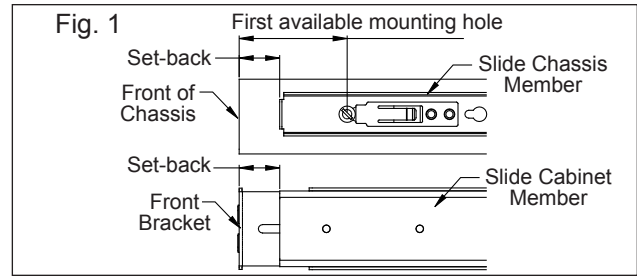

Slide Ordering Instructions

Complete your order by specifying the following:

Total Required Slides _____ 100 Pair C 2907 -22 WB D
 Slide Finish _____
 Model Number _____
 Slide Length _____
 Model Designation _____
 Distributor Packaging _____

Optional Mounting Accessories

Contact Accuride for alternative attachment methods.

Packaging

Distributor (D) Pack: Polybag packaging includes 1 pair of slides, 2 front brackets, 2 rear brackets, 8 each #8-32 thumb screws, 8 each #8-32 keep nuts. All lengths are packaged 5 pair per box.

Specifications

Slide members and Ball retainers: Cold rolled steel
 Ball bearings: Carburized steel

Note: Specifications, materials, prices, terms, and delivery are subject to change without notice.

Accuride

ACCURIDE INTERNATIONAL INC.

12311 Shoemaker Avenue
 Santa Fe Springs, CA 90670

TEL (562) 903-0200
 FAX (562) 903-0208
 www.accuride.com

Manufacturing, Engineering, and Sales
 United States • Germany • Japan • Mexico • United Kingdom • China